



EITEL-McCULLOUGH, INC.
SAN CARLOS, CALIFORNIA

EM-1080

VOLTAGE TUNABLE
MAGNETRON

FREQUENCY
1.2-2.2 kMc

MINIMUM OUTPUT POWER
100 mW

TYPICAL PERFORMANCE

ELECTRICAL

Frequency Range	1.2-2.2 kMc
Anode Voltage	800-1400 V
Cathode Current	2-15 mA
Typical Output Power	140-300 mW
Anode FM Sensitivity	1.68 Mc/V
Injection Anode Voltage	200 V
Injection Anode Current	0.1 mA
Heater Voltage (AC)	6.3 V
Heater Current (AC)	0.8 A
Load Impedance	50 ohms
Service	cw

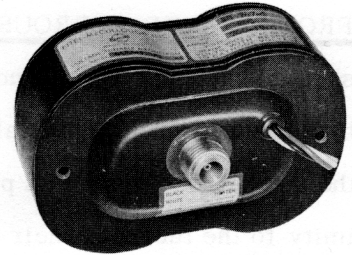

S-BAND
OSCILLATOR

*MAXIMUM RATINGS

Anode Voltage	1500 V
Cathode Current	25 mA
Injection Anode Voltage	+700 V
Injection Anode Current	1 mA

* Damage to the tube may occur if maximum ratings are exceeded.

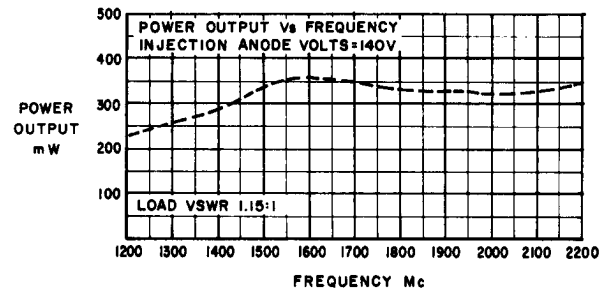

MECHANICAL

Operating Position	Any
Cooling	Conduction
Electrical Connection	Flexible Leads
RF Output Coupling	Type N Jack
Weight	3.5 Pounds

ENVIRONMENTAL

Vibration	10G-(to 2kc)
Shock	100G-(11ms)
Altitude	70,000 ft.

OUTLINE DIMENSIONS

Height	3 inches
Width	2.1 inches
Length	4.5 inches

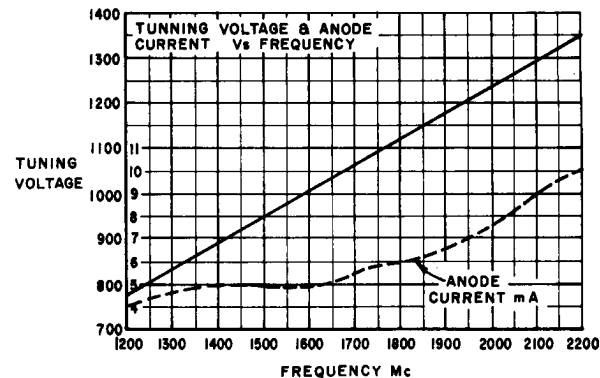



APPLICATION NOTES

- 1. COOLING:** To insure optimum tube performance the magnet temperature should be maintained below 70° C.
- 2. PROXIMITY OF FERROUS MATERIALS:** To minimize variations in performance, ferrous materials should be kept at least 6 inches from the magnetron package. Modulation of the tube may be produced by rotating ferrous materials and such parts as fans, shafts and couplings should be placed as far from the magnetron package as possible. Transformers and chokes should not be placed in such close proximity to the tube that their stray magnetic fields will interfere with the magnetron operation.
- 3. TEMPERATURE STABILITY:** The permanent magnet for the X-1080 has been temperature stabilized to minimize frequency changes caused by variations in the ambient temperature. The temperature/frequency coefficient for the X-1080 package is typically .02% of the operating frequency per degree Centigrade. Thus, for an operating frequency of 1500 megacycles, the temperature/frequency coefficient is typically 300 kilocycles per degree Centigrade. A positive change in temperature will always produce a positive change in frequency.
- 4. ANODE VOLTAGE:** The operating frequency is a function of the anode voltage; therefore, any voltage ripple on the anode supply will appear as frequency modulation on the RF output signal.

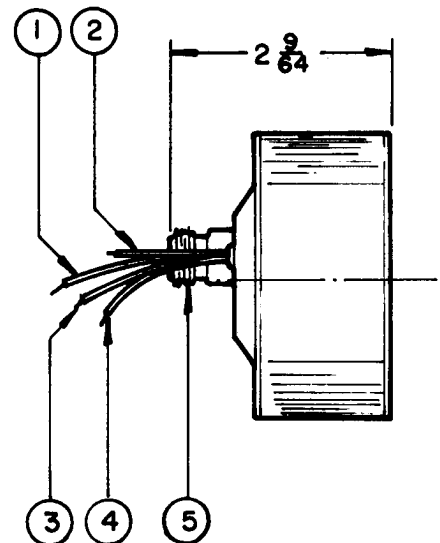
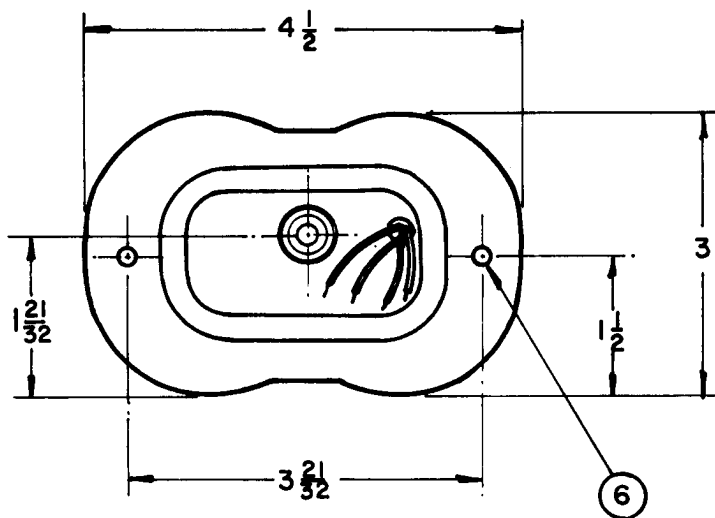

6	3/16 DIA. MOUNTING HOLES (2) REQ'D
5	FEMALE TYPE "N" CONNECTOR
4	GROUND LEAD (GREEN)
3	HEATER LEAD (WHITE)
2	HEATER CATHODE LEAD (BLACK)
1	INJECTION ANODE LEAD (YELLOW)